

The Daughter Nuclides of Protactinium-231. -Their Separations and Nuclear Properties

Takashi NAKANISHI and Masanobu SAKANOUÉ

*Radiochemical Laboratory, Department of Chemistry,
Faculty of Science, Kanazawa University*

(Received 9 April 1969)

A simple procedure for consecutive separation of Pa, Th, Ac, Ra, Fr, and Pb from each other was studied by using both anion and cation exchange resin column. By the proposed method, these elements were obtained in highly pure and carrier-free state easily after the coprecipitation with $\text{Fe}(\text{OH})_3$. That is, by using oxalate form of Dowex 1 x8 anion exchange resin and the following conversion of its form to chloride form, $\text{AcX} (^{223}\text{Ra}) + \text{Ac} (^{227}\text{Ac}) + \text{AcB} (^{211}\text{Pb})$, $\text{RdAc} (^{227}\text{Th})$, and $\text{Pa} (^{231}\text{Pa})$ were separated from each other and also from Fe carrier. Then, $\text{AcK} (^{223}\text{Fr})$, AcB, AcX and Ac which were not well separated from each other by the preceding procedure, were separated consecutively on Dowex 50 x8 cation exchange resin. Both α/γ spectra and decay curves of the separated nuclides were reported as nuclear properties.

1. Introduction

The elements which belong to natural radioactive series can be separated from each other by various methods including ion-exchange⁽¹⁾⁽²⁾, solvent extraction and coprecipitation etc.⁽¹⁾.

On the ion-exchange separation of daughter nuclides from Pa-231, the following studies have already been made. By the cation exchange method, Kirby⁽³⁾ separated ^{227}Ac , ^{227}Th and ^{223}Ra in the system of 0.05N HF and 1N HNO_3 solution and Andrews et al.⁽⁴⁾ separated one milligram of ^{227}Ac from one gram of neutron irradiated ^{226}Ra after the study of determining the distribution coefficients of Ra and Ac isotopes on Dowex50 as a function of HCl and HNO_3 concentration⁽⁵⁾. Cabell⁽⁶⁾ modified this method and Ra, Ac, and Th were stepwisely eluted from Dowex 50 column. As for the eluting agent, Radhakrishna⁽⁷⁾ used 5% citric acid (pH=3) for Ac at 81°C, and then 7% oxalic acid or 0.5M ammonium acetate (pH=4) for Th. A mixture of 8.5M $\text{HClO}_4 + 0.5\text{M HCl} + 0.1\text{M HF}$ was used as eluant by Nelson⁽⁸⁾ for the separation of both Ac and Th from other elements. Duyckaerts et al.⁽⁹⁾ studied the elution of Ac from a NH_4 form Dowex 50 column with 0.01M EDTA (pH=9). Actinium elution was also effected by 0.5M glycolic or α -hydroxyisobutyric acid (pH=4)⁽¹⁰⁾. The separation of ^{223}Fr from other members of the ^{227}Ac decay chain was accomplished

with 0.5M HClO_4 ⁽¹¹⁾ or by the other method⁽¹²⁾.

As mentioned above, many methods using cation exchange resin have been reported for the specific separation of a few member of actinium series. However, in most cases, they do not give a simple and stepwise separation of all these members from the parent Pa-231. So, it is desired to develop a method to separate and determine the daughter nuclides stepwisely from its parent.

In our earlier studies^(13a,b) on the ion-exchange separation of long-lived α -emitting nuclides; radium, thorium, protactinium and uranium were separated stepwisely from Fe carrier by using the oxalate form Dowex 1 x8 anion exchange resin and its conversion to chloride form. By the modification of this method, a simple and stepwise ion-exchange isolation of tracer amounts of Pa, Th, Ac, Ra, Fr, and Pb from Fe carrier was effectively carried out by using the nuclides which belong to the actino-uranium series (Fig. 1) and the results are reported here. The brief description of this separation method was published as short communication in *Radiochim. Acta*⁽¹⁴⁾, in advance.

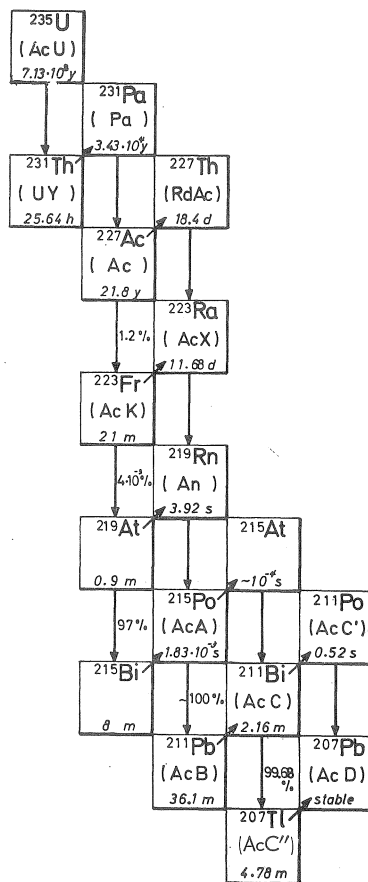

Fig. 1 The actino-uranium series

2. Experimental

2.1 Reagents and Materials

Ion-exchange resin used was Dowex 1 x8 anion exchange resin of 200-400 mesh size and Dowex 50 x8 cation exchange resin of 100-200 mesh size. Reagents for preparing the tracer solution and the eluting solution were of G.R. grade. The original Pa-231 solution, supplied by RCC, U. K. AEA, was 3M sulfuric acid solution. About 1 μCi of this solution was used for each column experiment. The α -spectrum (Fig. 2. a) and the γ -spectrum (Fig. 2. b) of this original solution show the existence of the daughter nuclides and the α -activity ratio of RdAc/Pa was observed to be about 0.15. The column filled with ion-exchange resin was of a 20 cm length and 8 mm or 6 mm I. D. glass tube. The bottom of the column was made slender and a wad of glass wool was used to keep the resin in the column.

2.2 Counting Equipments

The nuclides eluted from column were identified by their half lives and the spectra

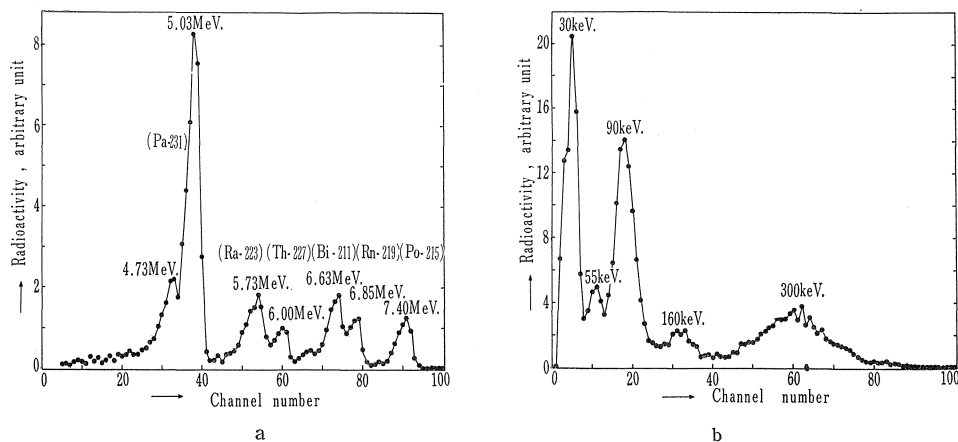

Fig. 2 a. Alpha spectrum of original Pa-231
b. Gamma spectrum of original Pa-231

of α - or γ -ray. The gross α -activity was counted with a ZnS(Ag) scintillation counter and the α -ray spectrum was taken by 100 channel pulse height analyzer (Model AN-100, Kōbe Kōgyō Co., Ltd.) coupled with double grided ionization chamber (Model No. 4, Ōsaka Dempa Co., Ltd.). The β -activity was counted with an end-window G. M. counter. The γ -activity was counted with a scintillation counter having a well type NaI(Tl) crystal ($1\frac{3}{4}'' \times 2''$), and the γ -spectrum was taken by 100 channel pulse height analyzer coupled with this detector. The counting source was prepared by electro-deposition or evaporation of sample solution on gold-coated copper plate for α - or β -assay whereas the γ -counting was carried out for each eluted solution directly.

3. Experimental Procedures and Results

3.1 Preparation of Column

Dowex 1 x8 anion exchange resin (Cl-form) was washed with 8M HCl solution, followed by the washing with distilled water to remove some impurities. Then, the resin was converted from chloride form to oxalate form with 0.5M oxalic acid solution. The Dowex 1 x8 resin thus treated was filled in a separation column of 8 mm I. D.. The resin bed was made to be 5 cm high. The flow rate of the eluting solution from this column was about 0.4 ml/cm²/min.

Dowex 50 x8 cation exchange resin (H-type) was washed with diluted HCl solution. Then it was introduced into a column of 6 mm I. D.. The resin bed was 8 cm high and the flow rate was about 0.7 ml/cm²/min. The resin bed was usually pre-treated by washing with several column volumes of the solution having the same composition as that used subsequently for elution.

3.2 Anion-Exchange Separation

About 1 μ Ci of the original Pa-231 in 3M sulfuric acid was taken in a polyethylene test tube and about 5 ml of distilled water and 10 mg of Fe carrier was added to

this solution. After heating in a water bath, ferric hydroxide was precipitated from this solution by ammonia gas. This precipitate was separated by centrifugation and washed with hot water containing ammonia. Then, this precipitate was dissolved in 0.5M oxalic acid solution. This oxalic acid solution was, then, introduced into an anion exchange resin column which had been previously treated with oxalic acid solution. The washing of anion exchange column with 0.5M oxalic acid solution was

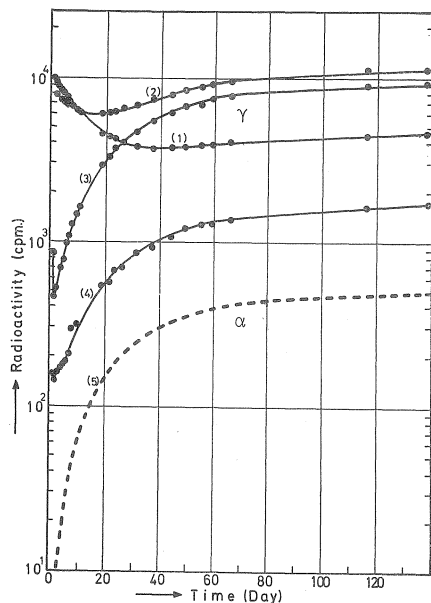

Fig. 3 Radioactive decay and growth curves of 0.5M oxalic acid fraction from Dowex 1 x8 anion exchange column

carried out subsequently. In this procedure, every 2-3 ml of the eluate was fractionally collected in a polyethylene test tube, followed by the assay for α -, β -, and γ -activity. In this procedure, it was confirmed from the decay and growth curve of the γ -radioactivity in these 0.5M oxalic acid eluate (Fig. 3) that AcX (^{228}Ra : $T_{1/2}=11.69$ d), AcB (^{211}Pb : $T_{1/2}=36.1$ m), and Ac (^{227}Ac : $T_{1/2}=21.8$ y) passed through the column in this order. Because, the initial γ -activity of fraction (1) and (2) of oxalic acid solution shows the decay of AcX and that of fraction (3) shows the decay of AcB. With the lapse of time, all the fraction (1)-(4) show a growth of the γ -radioactivity. The dotted line (5) on Fig. 3 is the theoretical growth curve of daughter α -activities (RdAc, AcX, An, AcA, and AcC) from initially pure Ac. The growth part of the curves (1)-(4) obtained

in the experiment can be explained by this theoretical growth curve. In reference to these facts, if the 0.5M oxalic acid eluants are collected little by little fractionally, it may be possible that AcX, AcB, and Ac are separated from each other with little cross-contamination.

On the other hand, Pa (^{231}Pa : $T_{1/2}=3.43 \times 10^4$ y), RdAc (^{227}Th : $T_{1/2}=18.4$ d) and Fe were caught on the oxalate form anion exchange column. The elution of RdAc caught on Dowex 1 x8 was realized with the eluant of 8M hydrochloric acid solution. The radiochemical purity of RdAc in this fraction was examined by α - (Fig. 4.a-A) and γ -spectrum (Fig. 4.b), and this was also confirmed by measuring both the growth and decay of α -radioactivity (Fig. 4.c) and the change of α -spectrum with time (Fig. 4.a). After the elution of RdAc, protactinium was eluted with 8M HCl + 0.1M HF mixed solution, and the radiochemical purity of Pa was well confirmed by its α - (Fig. 5.a) and γ - spectrum (Fig. 5.b) and the complete removal of its daughter nuclides is evident in comparison of these spectra with that of original solution. The radiochemical yield of Pa-231 and Th-227 in this ion-exchange procedure was almost

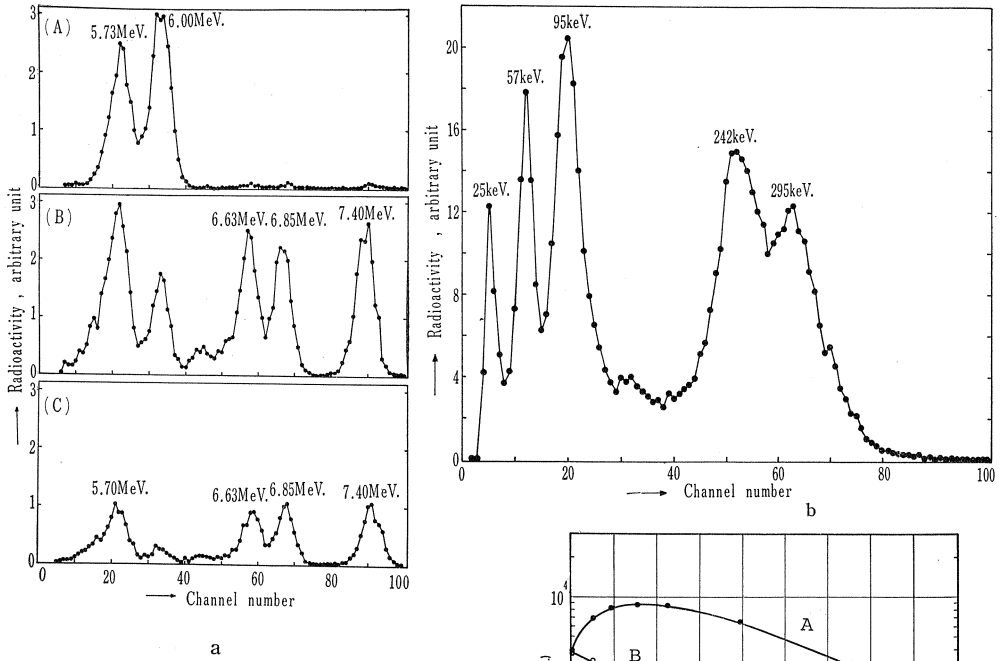

Fig. 4 a. Alpha spectra of RdAc fraction

(A) 3 hours after the electrodeposition,
 (B) 22 days after the electrodeposition,
 (C) 65 days after the electrodeposition.

b. Gamma spectrum of RdAc fraction

c. Decay of RdAc and growth of AcX
 from initially pure RdAc, A: total alpha
 activity, B: alpha activity of RdAc,
 C: alpha activity of AcX.

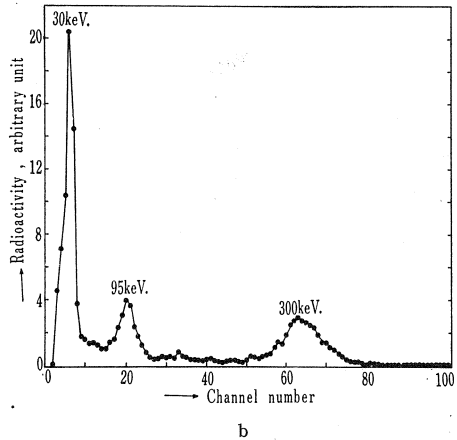
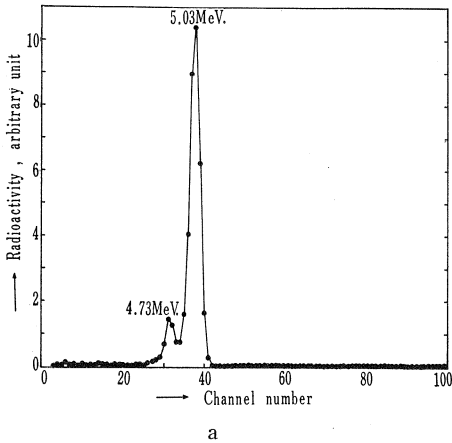
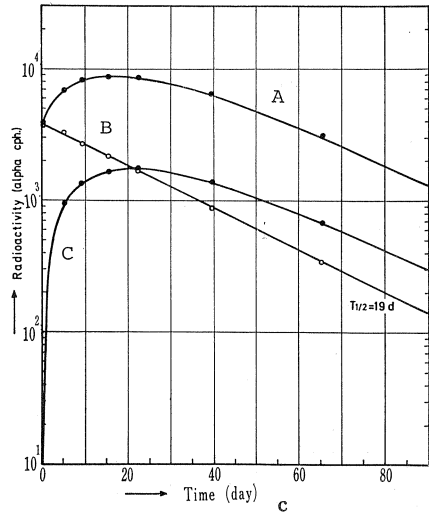

Fig. 5 a. Alpha spectrum of Pa fraction

b. Gamma spectrum of Pa fraction

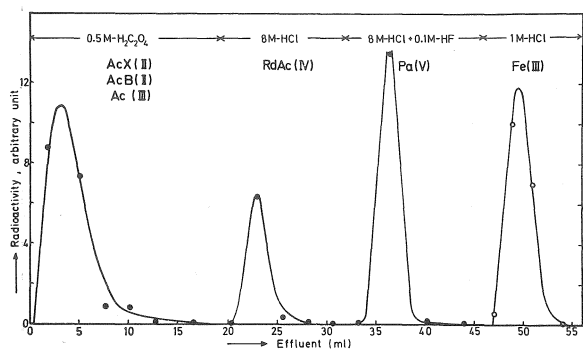

Fig. 6 Elution diagram of AcX, AcB, Ac, RdAc, Pa, and Fe from Dowex 1 x8 anion exchange column

3.3 Cation-Exchange Separation

After the anion exchange separation procedure, it is favorable to apply the cation exchange separation method mentioned below to the eluate of 0.5M oxalic acid, in order to obtain the more radiochemically pure AcX, AcB and Ac. Because the fractional collection of the 0.5M oxalic acid effluent to separate AcX, AcB, and Ac is troublesome and not so effective.

The 0.5M oxalic acid effluent from anion exchange resin was introduced directly into a Dowex 50 x8 cation exchange column of H-form, which was previously conditioned with oxalic acid solution. After feeding of the mixture of AcX, AcB, and Ac, small amount of AcB activity was detected in the washing solution of 0.5M oxalic acid solution. Then the column was subjected to the stepwise elutions with the eluants of different concentration of hydrochloric acid. At first, in the effluent eluted with 0.1–0.5M HCl solution, nuclide having short half life of about several minutes was found. It might be AcC (^{211}Bi : $T_{1/2}=2.16\text{ m}$) or AcC'' (^{207}Tl : $T_{1/2}=4.78\text{ m}$). Then, by using 1–2M HCl solution as a eluant, AcK (^{228}Fr : $T_{1/2}=21.8\text{ m}$) and AcB with its daughters were eluted. Furthermore, with 4–8M HCl, AcX was eluted, though the eluant of ten times as much as column volume was required to elute AcX completely. After most part of AcX was eluted, Ac began to break through from the column resin bed. When the elution was stopped at this stage, only Ac was remained on resin. This circumstance was confirmed by the fact that the milking of AcK which attained to the radioactive equilibrium with the parent Ac in about two

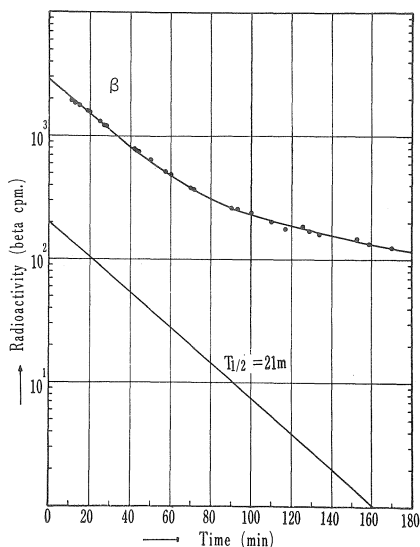

Fig. 7 Decay curve of AcK fraction

100%. Finally, iron can be eluted completely with 1M HCl solution. Thus, by the simple method using the oxalate form anion exchange column, it was accomplished to isolate RdAc and Pa respectively in high radiochemical purity and carrier-free state. As a summary, in Fig. 6, the elution curves of the respective nuclides separated with the above mentioned method was schematically shown.

hours was realized on Dowex 50 x8 column with the eluant of 1M HCl. The beta decay curve of this effluent is shown in Fig. 7 and the measured half life agrees with that of AcK in the initial part of this curve. With 6M HNO₃, Ac remaining on the column could be easily eluted. It was also found that the elution of AcK was possible with 0.5M HClO₄. With this eluant, only AcK was eluted, though AcX or AcB remained on resin.

Furthermore, for the above-mentioned procedure, some improvements were developed as follows

The elution of AcB could be made with 1–2M HCl (Fig. 8. A), but this elution was facilitated by the addition of methanol to HCl eluant (Fig. 8. B). In the eluate

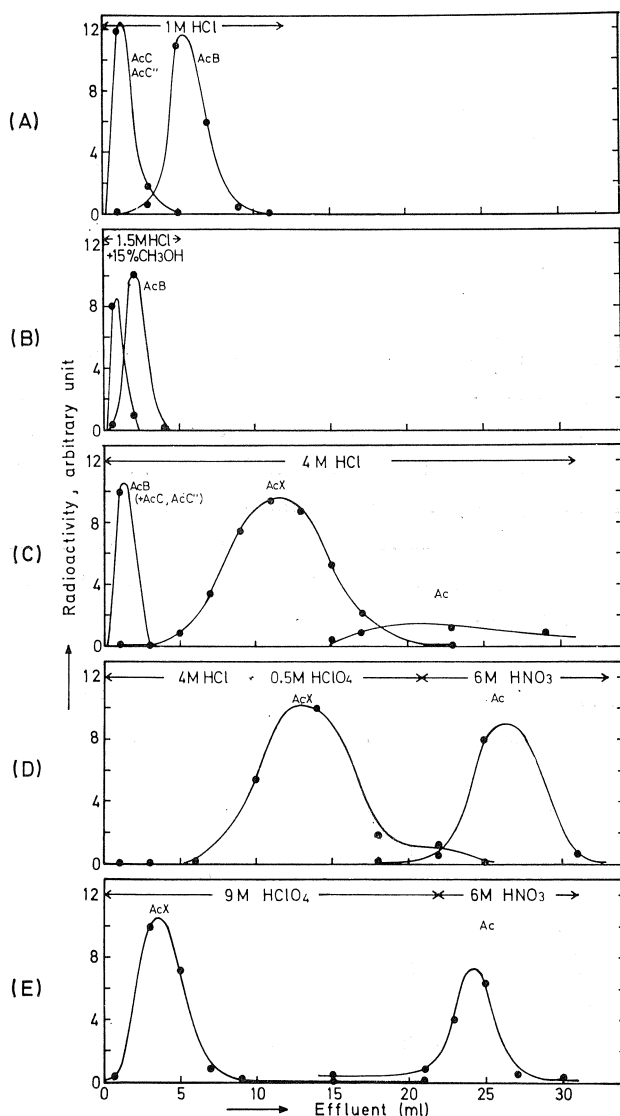

Fig. 8 Elution of AcB, AcX and Ac from Dowex 50 x8 cation exchange column

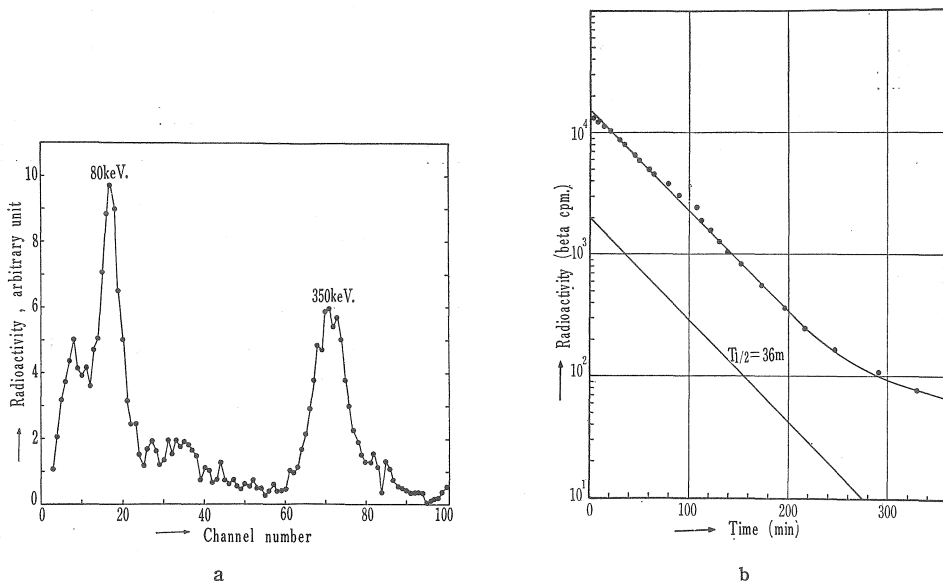
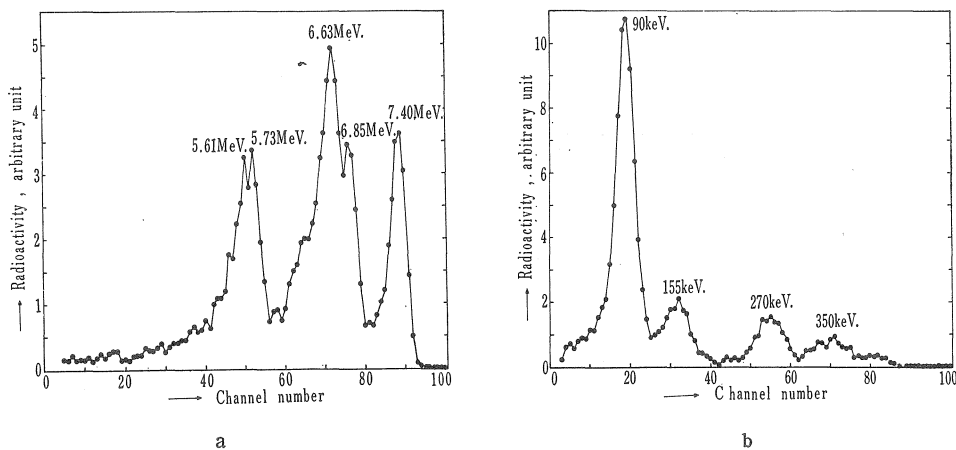

Fig. 9 a. Gamma spectrum of AcB and its decay products
b. Decay curve of AcB fraction

with 1.5M HCl + 15% CH₃OH, AcB was identified through its γ -spectrum (Fig. 9.a) and its decay curve (Fig. 9.b).

If the elution with 4M HCl continued too long as shown in Fig. 8.C, the contamination with small amount of Ac was found in AcX fraction. In this case, the addition of small amount of HClO₄ to 4M HCl eluant makes some retardation of the elution of Ac (Fig. 8.D). If the elution of AcX was carried out with 9M HClO₄, it was easier to elute this nuclide than the elution with 4M HCl as shown in Fig. 8.E. Though very small amount of Ac began to break through after most part of AcX was eluted, it was accomplished to obtain radiochemically pure AcX with high recovery by discarding the final part of AcX fraction. Both the α - and γ -spectrum of AcX are



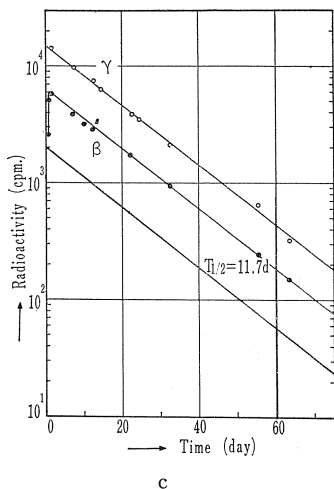

Fig. 10 a. Alpha spectrum of AcX and its decay products
 b. Gamma spectrum of AcX fraction
 c. Decay curve of AcX fraction

shown in Fig. 10.a and b. The decay curve of β - and γ -activity are consistent with its half life (11.7 d) as shown in Fig. 10.c.

From above mentioned results, it became possible to separate AcK, AcB, AcX, and Ac from each other by stepwise elution with 5-20 ml of the eluants such as 0.5M HClO₄, 1.5M HCl + 15% CH₃OH, 9M HClO₄, and 6M HNO₃, respectively on Dowex 50 x8 column. The elution curves of these procedures are shown schematically in Fig. 11. The radioactivities for AcK, AcB, and AcX are measured immediately after the elution, but those for Ac are shown indirectly by the gross activity of daughter nuclides grown up after about 100 days, because the radioactivity of Ac itself is too weak to measure.

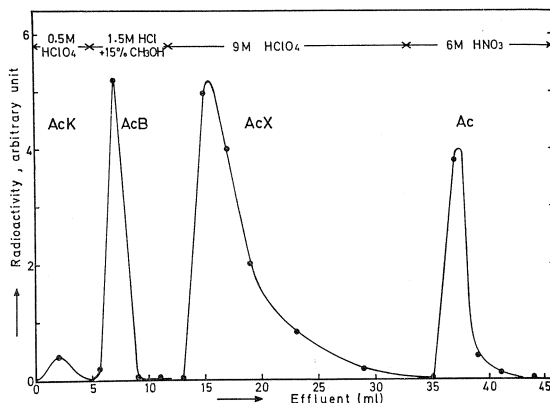

Fig. 11 Elution diagram of AcK, AcB, AcX and Ac from Dowex 50 x8 cation exchange column

After all, the daughter nuclides of Pa-231 were isolated in carrier-free state and in high purity by this simple procedure. Furthermore, it must be pointed out that the treatment of the eluted solution is easy after this separation method, because the eluant is the solution containing the acid which can be removed by evaporation without any residue.

REFERENCES

1. a) W. M. Gibson, "The Radiochemistry of Lead", NAS-NS 3040.
b) E. K. Hyde, "The Radiochemistry of Francium", NAS-NS 3003.
c) H. W. Kirby, "The Radiochemistry of Radium", NAS-NS 3057.
d) P. C. Stevenson and W. E. Nervik. "The Radiochemistry of the Rare Earths, Scandium, Yttrium, and Actinium", NAS-NS 3020.
e) E. K. Hyde, "The Radiochemistry of Thorium", NAS-NS 3004.
f) H. W. Kirby, "The Radiochemistry of Protactinium", NAS-NS 3016.
2. J. Inczedy "Analytical Application of Ion-Exchangers" (1966), Pergamon, London.
3. H. W. Kirby, USAEC Report NAS-NS 3016 (1959).
4. F. Hagemann and H. C. Andrews, USAEC Report ANL-4215, 15 (1948).
5. H. C. Andrews and F. Hagemann, USAEC Report ANL-4176, 13 (1948).
6. M. J. Cabell, Can. J. Chem., **37**, 1094 (1959).
7. P. Radhakrishna, J. Chim. Phys., **51**, 354 (1954).
8. F. Nelson, J. Chromatog., **16**, 538 (1964).
9. G. Duyckaerts and R. LeJeune, J. Chromatog., **3**, 58 (1960).
10. K. S. Bhatki and J. P. Adloff, Radiochim. Acta, **3**, 123 (1964).
11. J. F. Eichelberger, G. R. Grove and L. V. Jones, USAEC Report MLM-1266 (1965).
12. K. H. Lieser and E. Kluge, Radiochim. Acta, **7**, 3 (1967).
13. a) K. Komura and M. Sakanoue, Japan Analyst, **16**, 114 (1967).
b) M. Sakanoue, K. Konishi and K. Komura, IAEA STI/PUB/152, 313 (1967).
14. T. Nakanishi and M. Sakanoue, Radiochim. Acta, **11**, 119 (1969).